

MANISCOPIC

MT 1740
SLT & SLT ULTRA





- Maximum lifting height : 16.65 m
- Nominal capacity :
4000 kg at 500 mm
- Maximum forward reach : 12.35 m
- Torque convertor
- 4 wheel drive - 4 wheel steer
- Hydraulic stabilizers
- Frame levelling



RAM SERVICE S.R.L.
VIA DELLA BURCHIELLA 15 - 48122 RAVENNA
TEL. 0544.456182 - FAX 0544.600724
E-MAIL RAM@RAM-SERVICE.IT
URL : WWW.RAM-SERVICE.IT

MT 1740 SLT/SLT ULTRA

 **Lift capacity**4000 kg
at 500 mm from forks heels.
Tipping load at maximum reach
with stabilizers957 kg
Tear out force with bucket
as per ISO 83137000 daN

 **Lift height**16.65 m
Times : unladen / loaded (in s)
Lifting15/16
Lowering10/9
Extension 1st and 2nd booms21.8/24.4
Extension 3rd boom (with stabilisers only) ..10.4/11.5
Retraction 1st and 2nd booms17.7/17.4
Retraction 3rd boom (with stabilisers only)9.7/8.7
Time unladen (in s)
Crowd5.3
Dump8.4

 **Tyres**
440/80-24

 **Forks (mm)**
Length1200
Width x thickness125 x 50
Maximum distance between forks1040
Carriage rotation124°

 **Multidisc brakes - hydraulically assisted
on both axles**

 **PERKINS Engine Turbo**
Type1104C- 44 Turbo
Capacity4 cylindres 4400 cm³
Power (ISO/TR 14396) :
at 2200 tr/mn100 HP/74.5 kw
Maximum torque (ISO/TR 14396) ..412 Nm at 1400 r.p.m.
Direct Injection
Water Cooling

 **Transmission**Torque convertor
Electro-hydraulic reversing shift
4 gears forward and reverse
Maximum travel speed25 km/h

 **Hydraulics**
Gear type260 bars/196 l/mn
Flow divider with priority to steering and brakes

 **Capacities**
Cooling system18.5 l.
Engine oil11 l.
Hydraulic oil175 l.
Transmission oil16 l.
Fuel tank135 l.

 **Weight unladen (with forks)**11220 kg
Overall width2.42 m
Overall height2.60 m
Turning radius (outside wheels)4.17 m
Overall length5.98 m
Ground clearance0.48 m
Drawbar pull (unladen)9700 daN

Under
EN 1459
annexe B

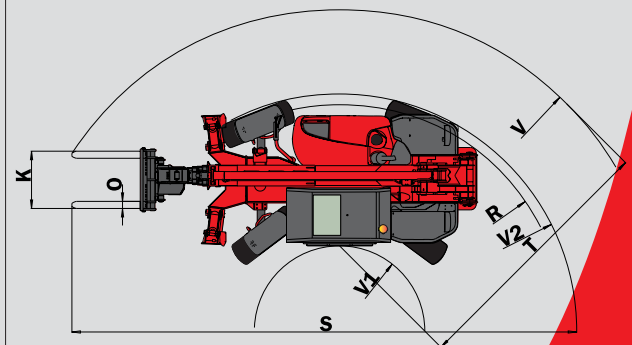
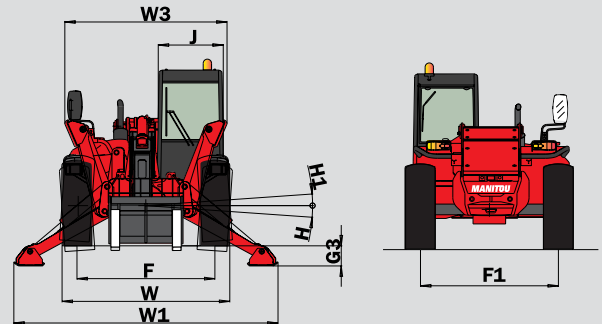
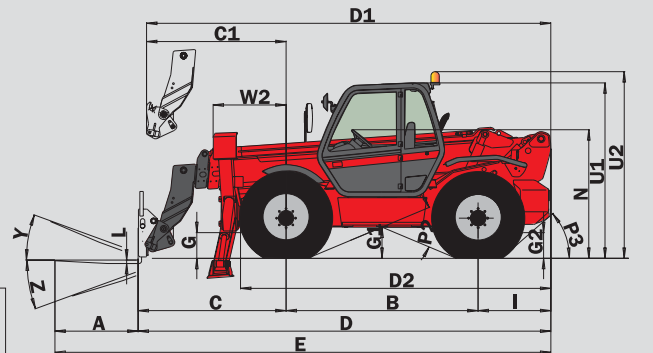
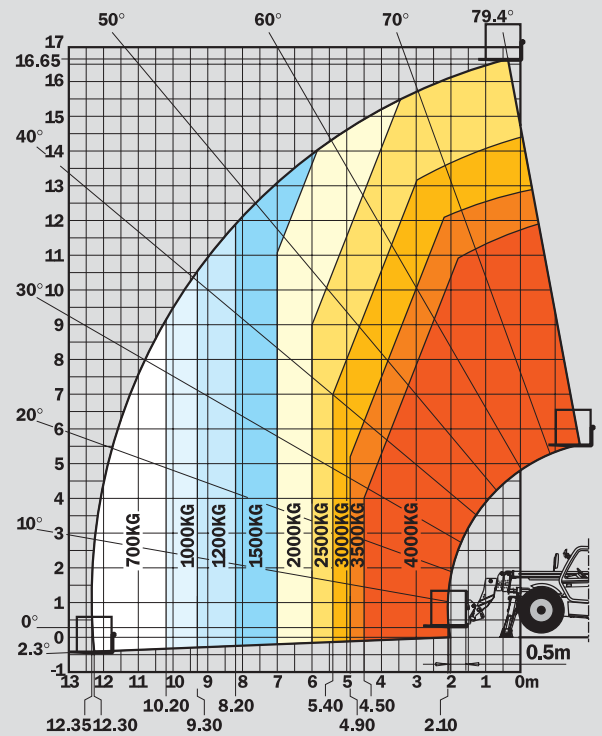

A	1200
B	2770
C	2160
C1	2232
D	5980
D1	6052
D2	4435
E	7180
F	1990
F1	1990
G	480
G1	475
G2	480
G3	290
H	7°
H1	7°
I	1050
J	950
K	1040
L	50
N	1880
O	125
P2	45,5°
P3	50°
R	3950
S	8912
T	4239
U1	2605
U2	2785
V	5709
V1	1470
V2	4168
W	2425
W1	3820
W2	1050
W3	2350
Y	12°
Z	112°